

# *Retain* YOUR *independence*



## **The Acorn Superglide Outdoor Stairlift**

The Acorn Superglide Stairlift is one of the most technologically advanced stairlifts available, helping thousands of people worldwide to reclaim full access to their home or garden. It's the safe, comfortable and simple solution to difficulty with outdoor steps.

The outdoor stairlift has all the features of the indoor stairlift, but is designed and manufactured specifically for outdoor use.

The Acorn Superglide Outdoor Stairlift is ideal for situations involving any steps that are exposed to the elements, including garden steps, balconies, porches, verandas and garage or basement steps.

All metallic components are either made from aluminium, and are oil annealed or zinc plated before powder coating. Plastic components are heat and UV resistant, protecting the stairlift from colour fading and ambient heat damage.

You can rest safe in the knowledge that tens of thousands of homes worldwide have already enjoyed the Acorn experience.



G I V E   Y O U R   L I F E   A   L I F T <sup>®</sup>



# A WEALTH OF *features* FOR YOUR BENEFIT

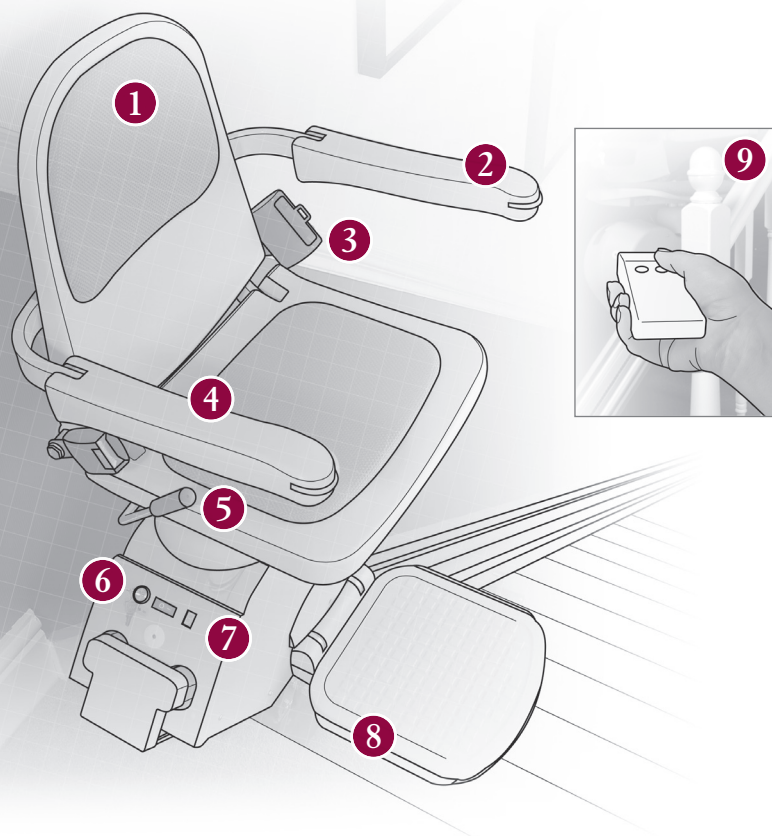

- 1 Padded seat and backrest.
- 2 Easy to use controls.
- 3 Secure safety belt.
- 4 Folding arms, footrest and seat allow easy access to the stairway.
- 5 Swivel seat - no need for twisting the body to get on and off the lift.
- 6 Lockable on/off switch allows the user to prevent others (e.g. children) from using the lift.
- 7 Diagnostic digital display informs the user of the status of the lift.
- 8 Five safety sensors on the footrest and carriage stop the lift automatically if any obstruction is encountered.
- 9 Hand-held remote controls allow users to 'call' or 'send' the lift up and down the staircase.

In addition to the features of the Acorn Superglide Indoor Stairlift, the Outdoor Stairlift comes with a durable waterproof cover for the ultimate in outdoor protection.



## Dimensions

		mm	inches
A	Width outside armrests	560	22
B	Width inside armrests	445	17.5
C	Width of backrest	370	14.5
D	Depth of seat	410	16
E	Top of footrest to seat	445	17.5
F	Required space from bottom of stair	660	26
G	Wall to seat width	40	1.5
H	Overall height of seat	495	19.5
I	Overall height	1020	40
J	Footrest surface to floor	115	4.5
K	Overall depth (folded)	325	13
L	Overall depth (footrest down)	585	23

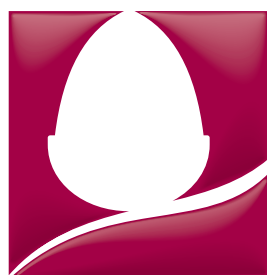
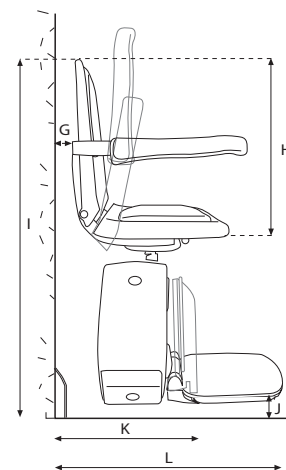
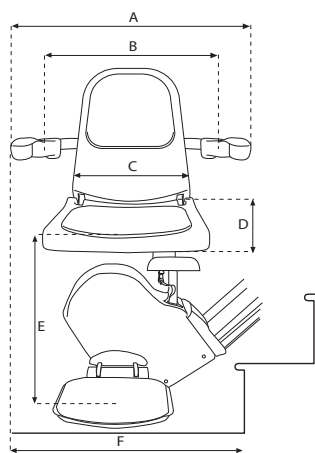

**ACORN**  
STAIRLIFTS

Dealer Stamp

## Specifications

Motor Power	0.25KW
Motor Output Speed	No greater than 0.15 m/s
Method of Drive	Rack and Pinion
Motor Output Torque	108Nm
Power Supply	24V DC (battery)
Maximum Capacity	127kgs
Track	Extruded Aluminium
Mains Supply	UK 240V, 50Hz Charger
	EC 220V, 50Hz Charger

Acorn, in keeping with its policy of continual development, reserves the right to change specifications without notice. All measurements are approximate. Images are shown for illustrative purposes only. Product may vary slightly.

ACOU/EXP0307

GIVE YOUR LIFE A LIFT®